

NOTE

If you don't have a plastic mallet, you can use a hammer with a wood block to protect the frame. If assembling on tile or wood, you must protect the floor.

Tool needed: plastic mallet

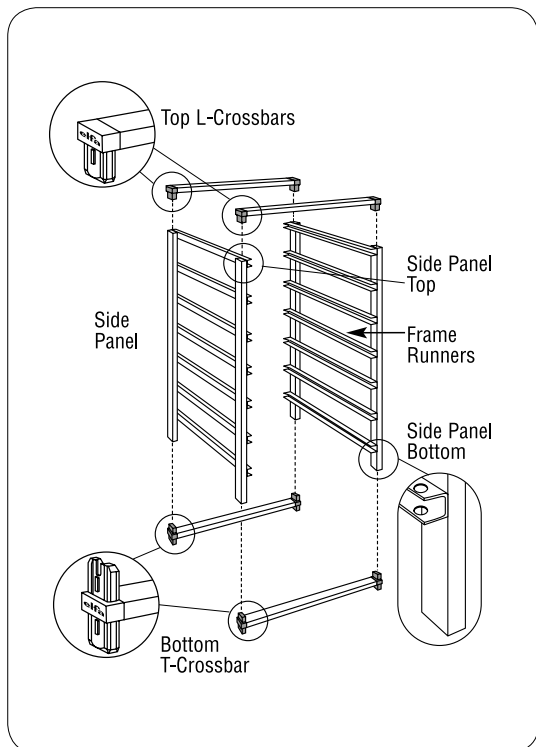

Assemble a single frame

Step 1

- Position the side panels so the frame runners face inward.
- Using a plastic mallet, tap the bottom T-crossbars into the bottom of each side panel.
- If combining frames, see Figure B below.

Step 2

- If using a top shelf, tap the top L-crossbars completely into each side panel. Place adhesive strips included in the packaging on the top L-Crossbars. Align the top shelf with the crossbars and press firmly.

Step 3

- Slide in drawers.
- If you have other frame and drawer accessories, install them now.

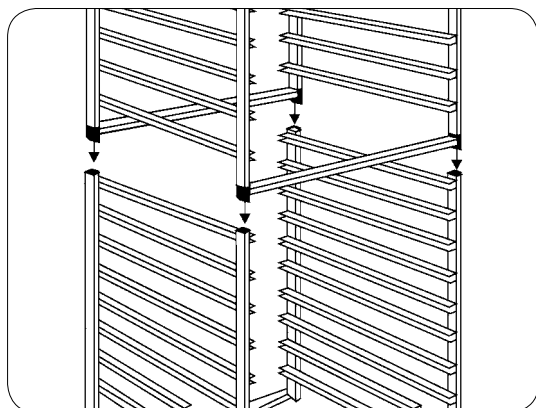

Combining drawer units

Step 1

- Assemble the top frame completely. See steps 1-2 above.

Step 2

- Assemble the bottom frame, omitting the top L-crossbars.

Step 3

- Lower the top frame onto the bottom frame. Secure by firmly tapping each corner of the top frame until the bottom T-crossbars are completely inserted into the bottom frame.

Step 4

- Slide in drawers.
- If you have other frame and drawer accessories, install them now.

